

PRODUCT NO.  
 SEE SHEET 4

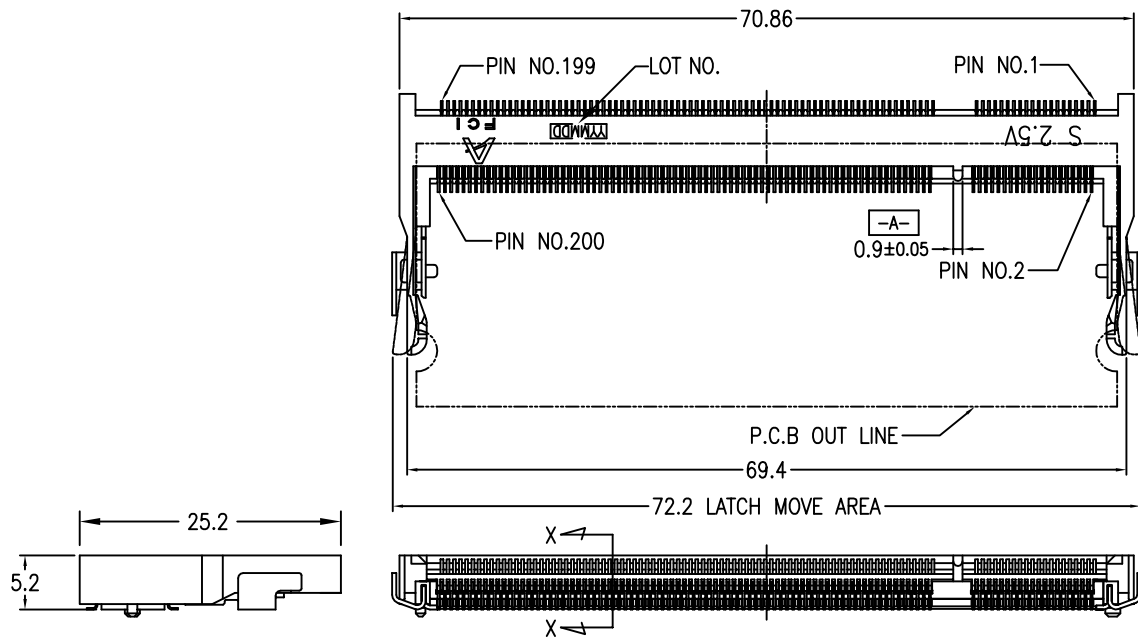

REVISIONS				
REV	DESCRIPTION	ECN	BY	DATE
2	REVISED		HS	11/29/01
3	REVISED		HS	1/16/02
4	REVISED		HS	2/22/02
5	REVISED		HS	8/14/02
6	REVISED		HS	10/ 9/02
7	REVISED		HS	10/10/02
A	RELEASED	J20561	HS	10/17/02
B	ADDED NEW P/N	J20623	HS	12/13/02
C	ADDED DIMENSION	J03-0065	HS	2/10/03
D	ADDED -052T, -152T	J03-0243	M.H	6/2/03
E	REVISED	J03-0305	M.H	7/17/03
F	REVISED & ADDED SHEET 4	J03-0434	M.H	11/10/03
G	REVISED	J04-0132	M.H	4/6/04
H	REVISED	T05-0022	R.C	01/27/05'
J	REVISED	T05-0026	RC	02/04/05'
K	REVISED	DG05-0388	K.W	10/13/05'

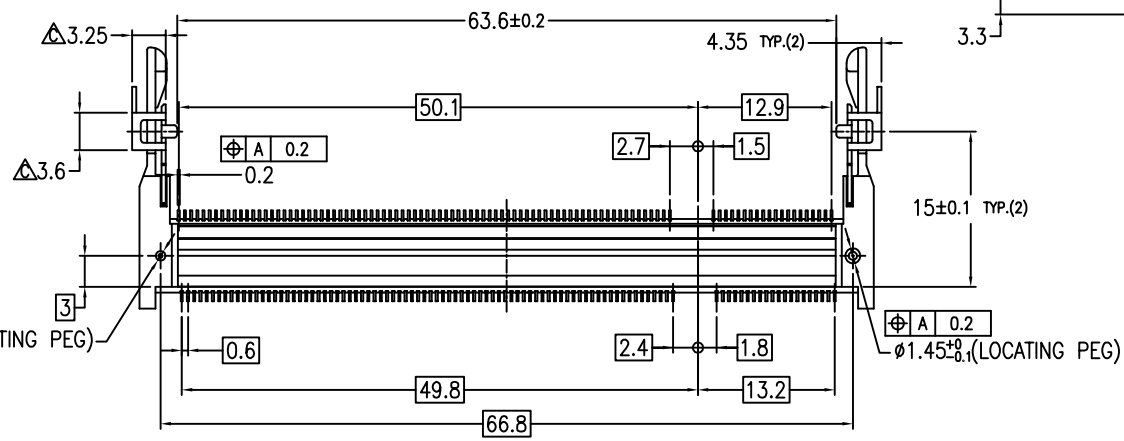
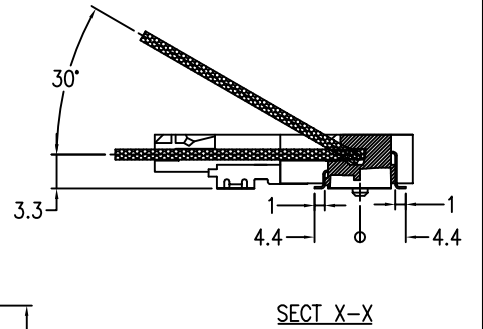

- NOTE
- PRODUCT SPEC. : GS-12-195
  - PACKAGING SPEC. : GS-14-786
  - MATERIAL
    - HOUSING : LCP, UL94V-0, COLOR BLACK
    - CONTACT : PHOSPHOR BRONZE
    - HOLD DOWN : BRASS
  - FINISH
    - TERMINAL : SEE TABLE  $\Delta$
    - HOLD DOWN : SEE TABLE  $\Delta$
  - CO-PLANARITY : 0.1 MAX.(INCLUDE HOLD DOWN)
  - THIS PRODUCT MEETS EUROPEAN UNION DIRECTIVES AND OTHER COUNTRY REGULATIONS AS DESCRIBED IN GS-22-008.
  - THE HOUSING WILL WITHSTAND EXPOSURE TO 260° PEAK TEMPERATURE FOR 10 SECONDS IN A WAVE SOLDER APPLICATION.

SHEET INDEX	ISSUE	K	F	E	J											
	SH NO.	1	2	3	4											
TOLERANCES UNLESS OTHERWISE SPECIFIED		MAT				DR		DATE		CUSTOMER COPY		TITLE				
±0.3		SEE NOTE				M.Hasegawa		10/01				DDR SO-DIMM 0.6 mm PITCH 200 POS. STANDARD TYPE ASSY				
LINEAR		FINISH				ENGR				THIRD ANGLE PROJ		PRODUCT FAMILY		CODE JP		
		SEE NOTE				M.Hasegawa						50UF SO-DIMM				
ANGLES	±2°					CHK				UNIT		SCALE	SIZE	DWG. NO.	REV	SHEET
						APPD				MM		2/1	B	59354	K	1 of 4

**FCI**

TITLE **DDR SO-DIMM 0.6 mm PITCH 200 POS. STANDARD TYPE ASSY**

PRODUCT FAMILY **50UF SO-DIMM**

SCALE **2/1** SIZE **B** DWG. NO. **59354** REV **K** SHEET **1 of 4**

DO NOT SCALE PRINT THIS INFORMATION IS CONFIDENTIAL AND IS DISCLOSED TO YOU ON CONDITION THAT NO FURTHER DISCLOSURE IS MADE BY YOU TO OTHER THAN FCI PERSONNEL WITHOUT WRITTEN AUTHORIZATION FROM FCI JAPAN K.K.

PRODUCT NO.

△ 59354-x52xx

REVISIONS

REV	DESCRIPTION	ECN	BY	DATE
1	SKETCHED		HS	9/27/'01
A	RELEASED	J20561	HS	10/17/'02
B	ADDED NEW P/N	J20623	HS	12/13/'02
C	ADDED -052T, -152T	J03-0243	M.H	6/2/'03
D	REVISED	J03-0305	M.H	7/17/'03
E	REVISED	J03-0434	M.H	11/10/'03
F	REVISED	D605-0388	K.W	10/13/'05

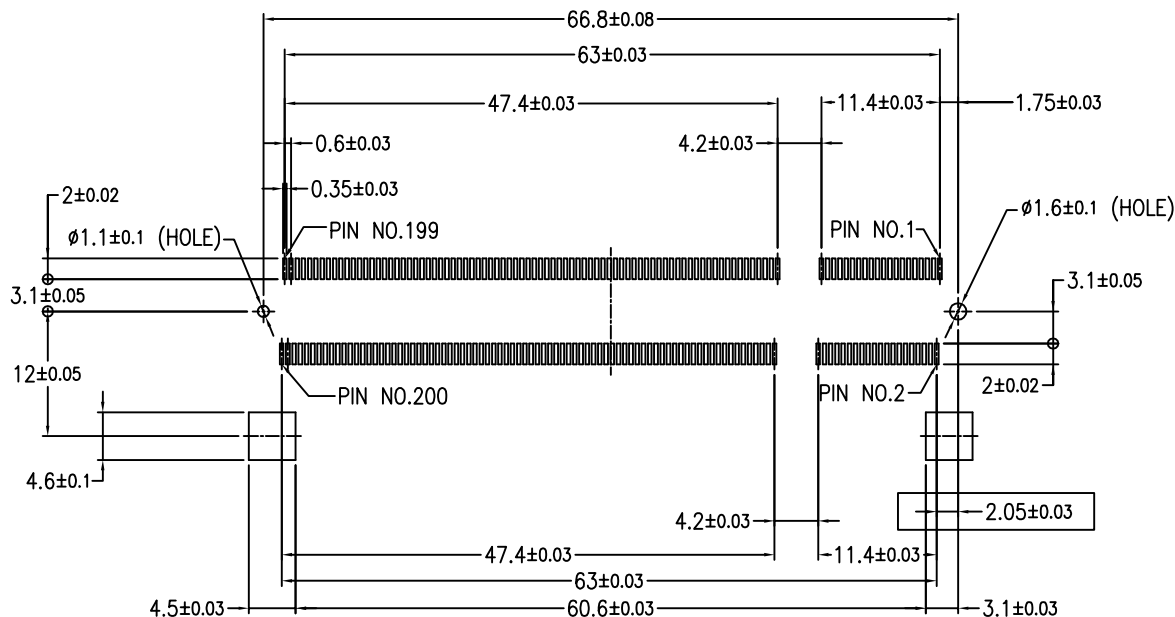

RECOMMENDED MOUNTING P.C.B LAYOUT



SHEET INDEX	ISSUE SH NO.											DR	DATE	CUSTOMER COPY	TITLE	CODE JP					
												M.Hasegawa	11/10/05		DDR SO-DIMM 0.6 mm PITCH 200 POS. STANDARD TYPE ASS'Y						
TOLERANCES UNLESS OTHERWISE SPECIFIED		MAT		ENGR		DATE		THIRD ANGLE PROJ		PRODUCT FAMILY		SCALE		SIZE		DWG. NO.		REV		SHEET	
±0.3		—H—		M.Hasegawa		11/10/05		THIRD ANGLE PROJ		50UF SO-DIMM		2/1		B		59354		F		2of	
LINEAR		FINISH		CHK		APPD		UNIT													
		—H—						MM													
ANGLES		±2°						INCH													

DO NOT SCALE PRINT THIS INFORMATION IS CONFIDENTIAL AND IS DISCLOSED TO YOU ON CONDITION THAT NO FURTHER DISCLOSURE IS MADE BY YOU TO OTHER THAN FCI PERSONNEL WITHOUT WRITTEN AUTHORIZATION FROM FCI JAPAN K.K.

DF-004A REV F



